



Processing Specification

MicroBridge IDC

ERNI Electronics GmbH & Co. KG

Seestrasse 9 | 73099 Adelberg / Germany | +49 7166 50-0 | www.erni.com

TABLE OF CONTENTS

1	Notes and Abbreviations	3
2	Fundamentals	4
3	Product Features.....	4
4	Cable Types.....	5
5	Tools	5
5.1	General.....	5
6	Processing Parameters	5
6.1	Pressing Forces	5
6.2	Pressing Speed.....	5
7	Assembly	6
7.1	Position of the Wire	6
7.2	Requirements for the Wire Ends and its Cutting Edges and Cutting Planes	9
7.3	Insulation Displacement (Insulation Cutting).....	10
7.4	Locking of the Cable Guide	11
7.4.1	Visual Characteristics.....	11
7.5	Pressing (Closing) the Connectors.....	12
7.5.1	90° cable outlet	13
7.5.2	180° cable outlet	15
7.5.3	Connector Housing Orientation during Pressing (Closing) the Housings ...	15
7.5.4	Check Dimension For Closed Connectors.....	16
8	Inspection.....	18
8.1	Applicable Inspections for Quality Assurance.....	18
8.2	Notes on Electrical Testing.....	19

Attachment I. Permissible Cables

Attachment II. Means Of Production

Change History

Change #	Description of Changes	Date (DE)
	Basis 4.4.2 6.3.4.5 V1	
04	Extended, finalized	30.01.20
05	Updated for 180° version type 2	01.09.20
06	Added newly-defined processing specifics for 90° and 180°	23.11.20
07	Updated Tolerance of check dimension 90°	8.12.20
08	Definition of wire position in cable guide for 180°-variant adjusted; clarification in 7.5.3; remark on isolation testing	01.06.21

1 Notes and Abbreviations

All processing shall strictly follow ERNI's Processing Specification in order to ensure best quality.

ERNI reserves the right to apply changes to this document without prior notice.

The released version of a Processing Specification can be obtained by download from www.erni.com. The edition on the website replaces all older versions, which hereby become invalidated. Make sure you regularly check there for more recent issues. If, in rare cases, the Processing Specification is not available online, please contact your local ERNI representative. This also applies to the Processing Specifications' attachments which may change independently from the main Processing Specification.

Products and product information in this document are meant to be of an educational nature and do not imply any assurance or guarantee including availability, qualification and approval, fitness for a certain application unless stated explicitly. For binding information always inquire directly with ERNI.

The visualisations in this document are of a schematical nature and adjusted for their respective purposes. For exact product representations we refer to product drawings and CAD models, which can be requested at ERNI.

The terms "cable" and "wire" are used synonymously and can be exchanged in the context of this document.

All dimensions are specified in the unit millimetre (mm) if not explicitly stated otherwise. "," may be used as a decimal delimiter instead of ".".

Abbreviations

IDC Insulation Displacement Connection

Terms

Pin position = pin number = number of the wire assembly position
 number 1 is marked at the connector housing of the receptacles; refer to
 respective product drawing

Number of poles = pin count = number of individual contact systems (circuits) per
 connector housing

References to Standards

DIN EN 60352-4
Lötfreie elektrische Verbindungen - Teil 4: Lötfreie nichtzugängliche
Schneidklemmverbindungen; Allgemeine Anforderungen, Prüfverfahren und
Anwendungshinweise; Deutsche Fassung EN 60352-4

(Solderless connections - Part 4: Solderless non-accessible insulation displacement
connections - General requirements, test methods and practical guidance)

IPC-A-620 now designated IPC/WHMA-A-620
Requirements and Acceptance for Cable and Wire Harness Assemblies

2 Fundamentals

The acceptance criteria for cable and cable harness assemblies according to the current edition of IPC-A-620 are generally recommended for assembly of the ERNI connectors.

3 Product Features

Number of poles: 2 to 20

Coding (mechanical with differing housing colors): black, blue, green, red

Cable outlet: 90° or 180°

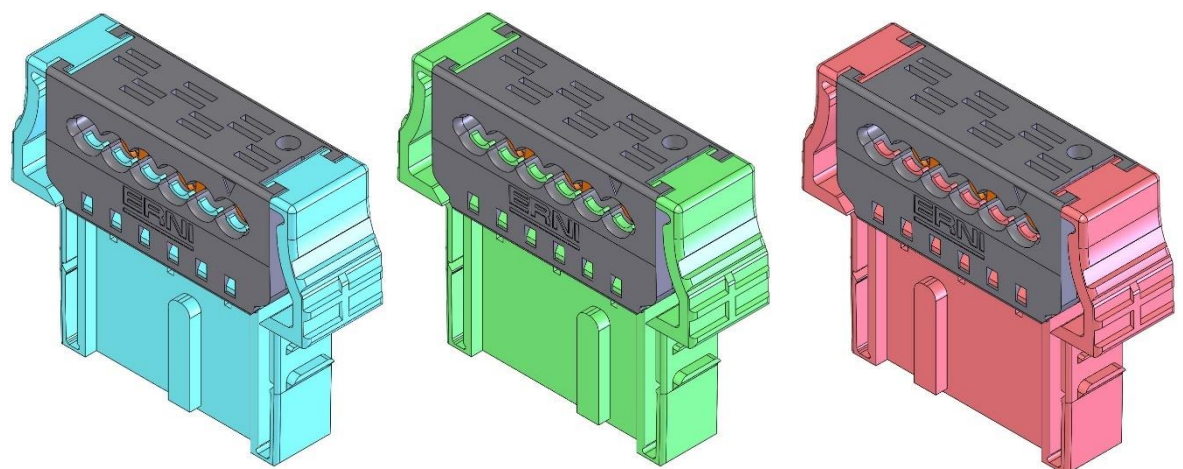
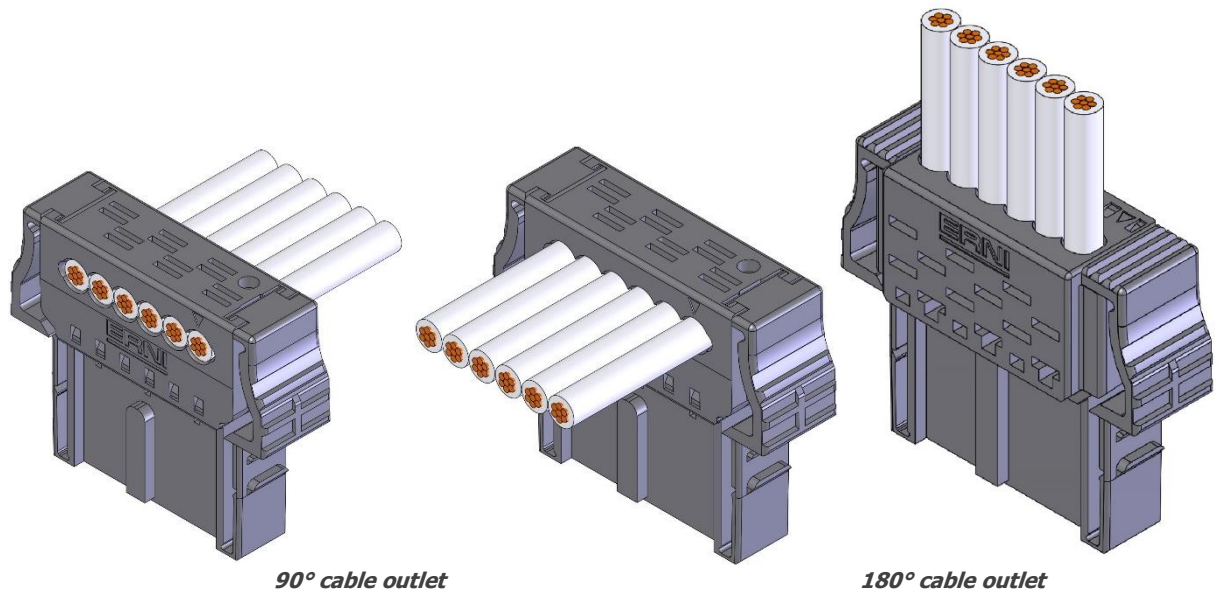

Visualisation of further coding variants

Note: The coding structures of the 6 to 20 pole receptacles are implemented identically for all numbers of poles. The coding of the 2, 3, 4 and 5 pole receptacles are implemented differently due to the small component size.

4 Cable Types

Only the wiring materials listed in Attachment I are permitted.

5 Tools

5.1 General

To protect the connector against damage (due to over-pressing), only tools that limit the pressing distance should be used to ensure that exceeding this seating limit (pressing distance) is not possible.

Tools must have sufficient clearances so that the locking mechanism cannot be damaged during the pressing process.

The usage of ERNI original tools is obligatory for manual processing. See Attachment II for an overview of the means of production. All other processing equipments (semi-automated or fully automated machines) must adhere to the requirements of this processing specification.

6 Processing Parameters

6.1 Pressing Forces

Forces of up to 300 Newtons per pin are required for processing the connectors, depending on the cable cross-section and insulation material. Whereby this is not a nominal value but a value for reference when considering various processing equipment; such as hand presses or other kinds of presses and should be adjusted accordingly.

Note: Simple manual tools used on toggle presses do not have any means to measure and monitor press forces.

Note: If a force or force-distance monitoring is desired, specific parameters and their tolerance must be individually determined by the customer as part of the overall process development.

6.2 Pressing Speed

A maximum pressing speed of 50 mm/s is recommended. Lower pressing speeds are allowed. Once a pressing cycle has started, it should not be interrupted.

When using toggle presses in manual mode, exceeding the maximum specified pressing speed is practically impossible.

7 Assembly

7.1 Position of the Wire

All positions of the cable guide of a receptacle connector housing shall be loaded with only one wiring material type (colour is irrelevant). Unused positions must always be loaded with a cable ("dummy cable"), even if they are not used electrically.

90° Cable Outlet

With the connector in the end position (cable beginning or cable ending), the cable tail shall be aligned flush with the connector housing and the cable guide, respectively.

The maximum permissible undercut of 0.3 mm in reference to the cable guide applies to the whole bundle of wire strands, as depicted in the figure below.

Undercut is a critical parameter of the assembly and its processing and must to be monitored, ensured, and achieved. Exceeding of the allowance results in reduced reliability.

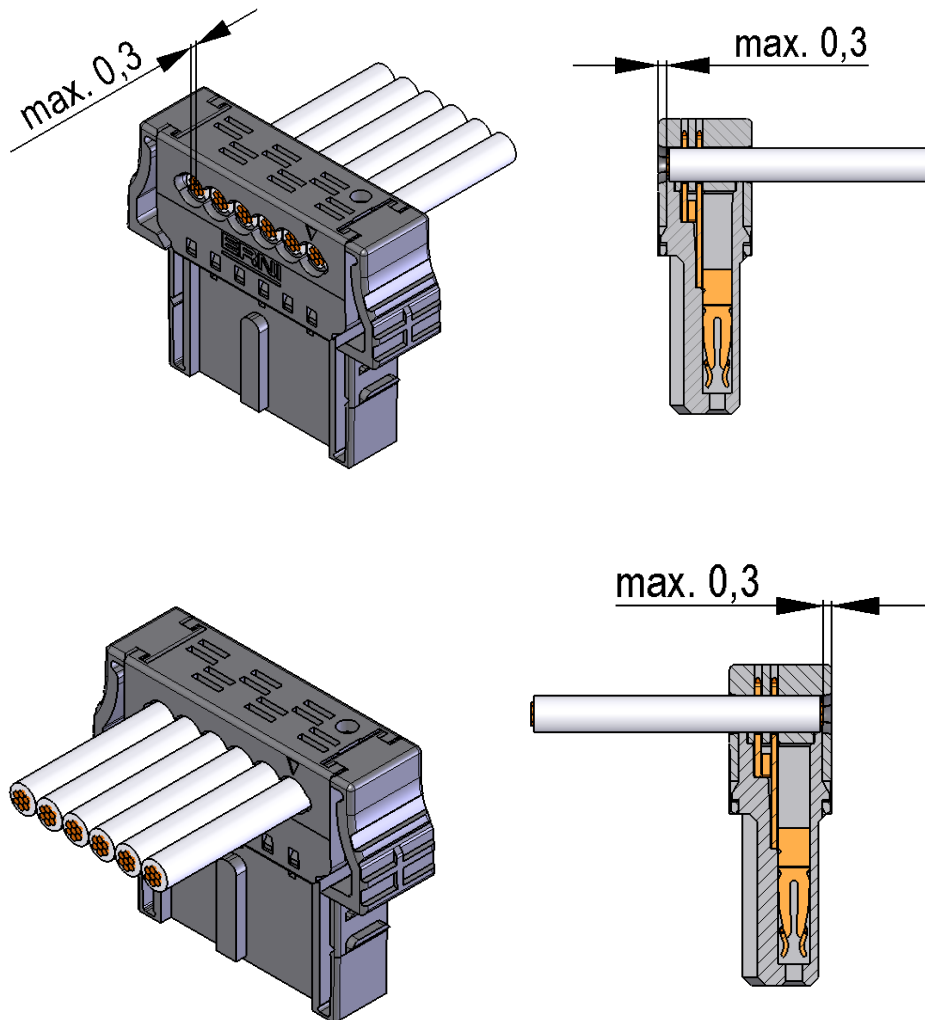

The **overhang** is not critical from a connector processing perspective and can be arbitrary. Thus, assemblies with a daisy-chain configuration, i.e. more than two connectors arranged on the length of the cable, are feasible.

The maximum permissible overhang depends on the needs of the concrete application for the cable assembly.

When the connector is in the end position (cable beginning or ending), a maximum overhang of 0.3 mm is recommended.

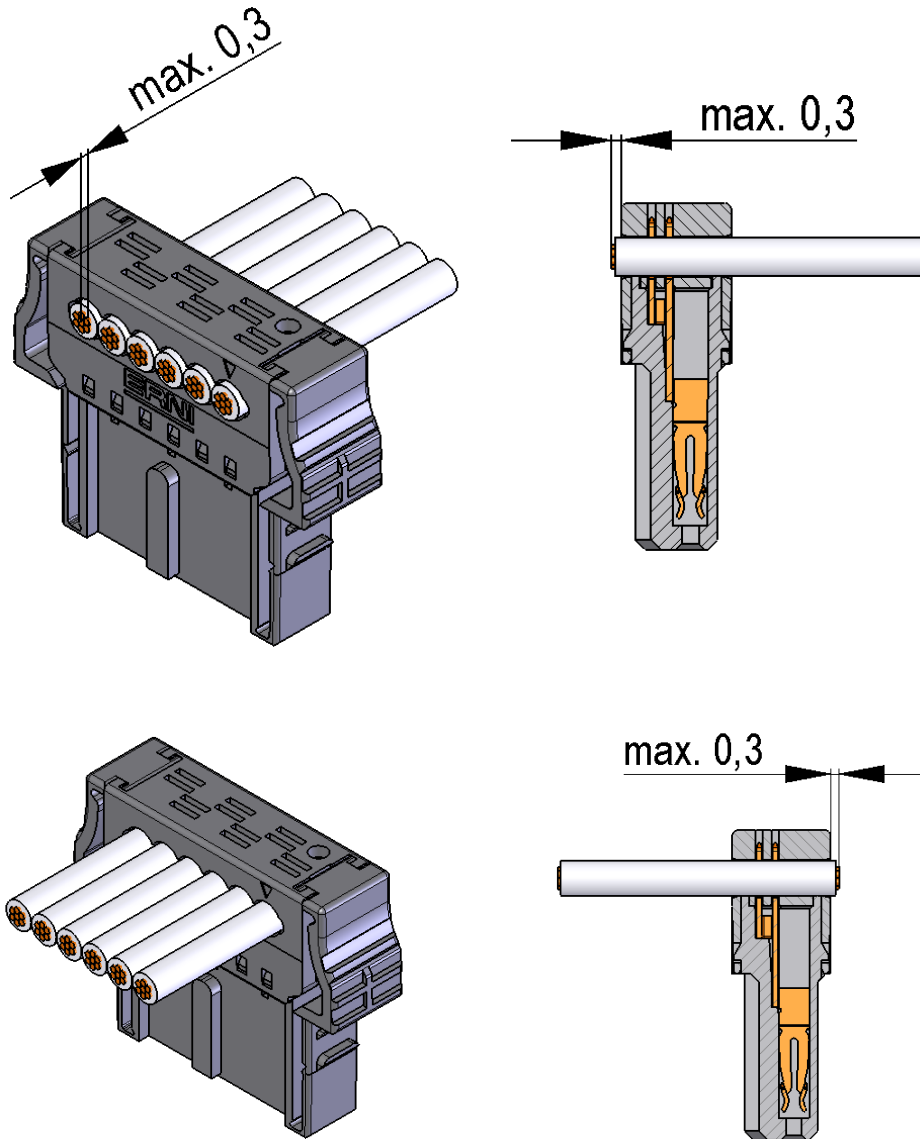

180° Cable Outlet

It is essential to achieve a sufficient insertion depth of the wire for the insulation displacement connectors with a 180° cable outlet and it is a critical parameter that needs to be monitored, ensured, and achieved. Failure to comply with the requirements may result in reduced reliability of the insulation displacement contacting.

The requirements to the insertion depth of the wires is different for even and odd numbers of the pin position.

For odd pin positions (1, 3, ...) sufficient insertion depth is ensured if the wire completely fills the inspection window, i.e. either insulation or copper strands lie against the end of the respective inspection window (refer to the tip of the blue arrow).

For even pin positions (2, 4, ...) sufficient insertion depth is ensured if the wire is visible in the respective inspection window (refer to the tip of the green arrow).

The requirements to the edges of the cut, described in section 7.2, have to be respected.

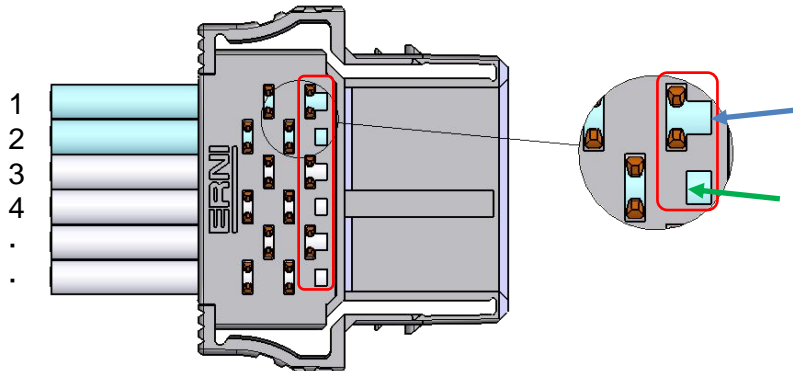

180° Receptacle with inspection windows and wires

7.2 Requirements for the Wire Ends and its Cutting Edges and Cutting Planes

The wires have to be cut in a way that they can be brought to their correct final loading position without issues. A clean transection shall be achieved. The insulation shall be cut without burrs and fringes and also without a significant deformation.

The strands shall be cut within a tolerance of 0.1 mm to the same length. The bundle of strands must not be deformed in the region, where the insulation-displacement contact will cut through the insulation.

Requirements and criteria of IPC-A-620 section 3 "Preparation" are to be applied as far as applicable. Class 3 is used if there are no application-specific aspects that allowed a lower classification.

Retraction of the bundle of strands from the insulation ends (undercut position of strands in the cable) or retraction of the insulation from the ends of the strands (overhang of the strands in the cable) is allowed to be a maximum of 0.1 mm in order to achieve a correct electrical connection in the ID contact system.

Retraction $\leq 0,1$ mm

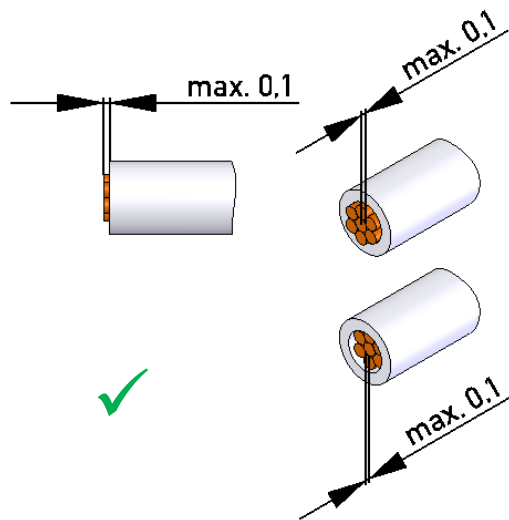

Retraction $> 0,1$ mm

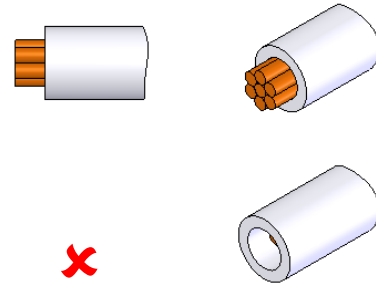

7.3 Insulation Displacement (Insulation Cutting)

Evaluated by visibility of the insulation displacement contact feature (ends) in the clamping shaft.

90° Cable Outlet

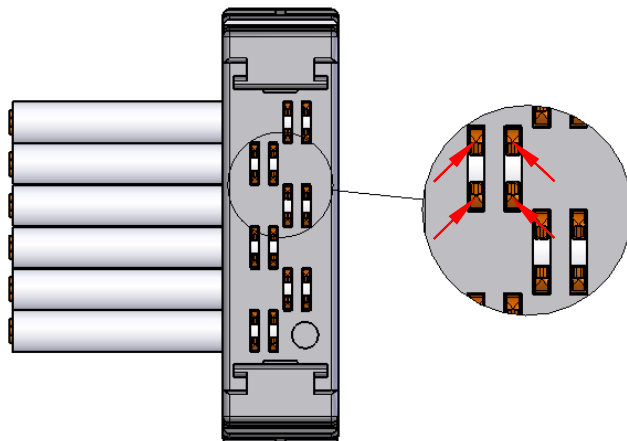

180° Cable Outlet

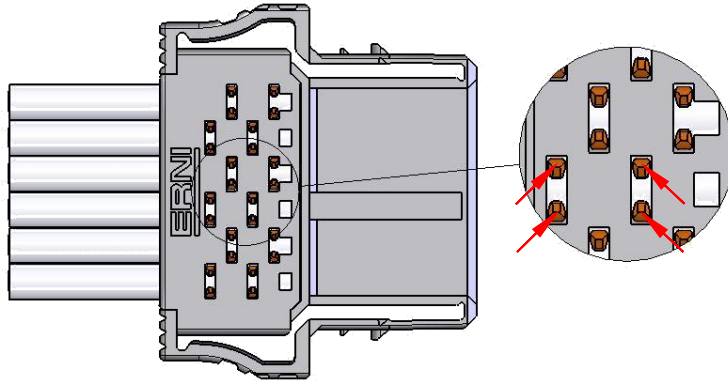

7.4 Locking of the Cable Guide

7.4.1 Visual Characteristics

There is a catch mechanism for each wire position in the receptacle connector housing which comprises a latching nose and a latching window. All latching noses need to snap into their respective latching windows and be completely visible there.

Note: Bulging of the cable guide indicates incomplete latching.

90° Cable Outlet

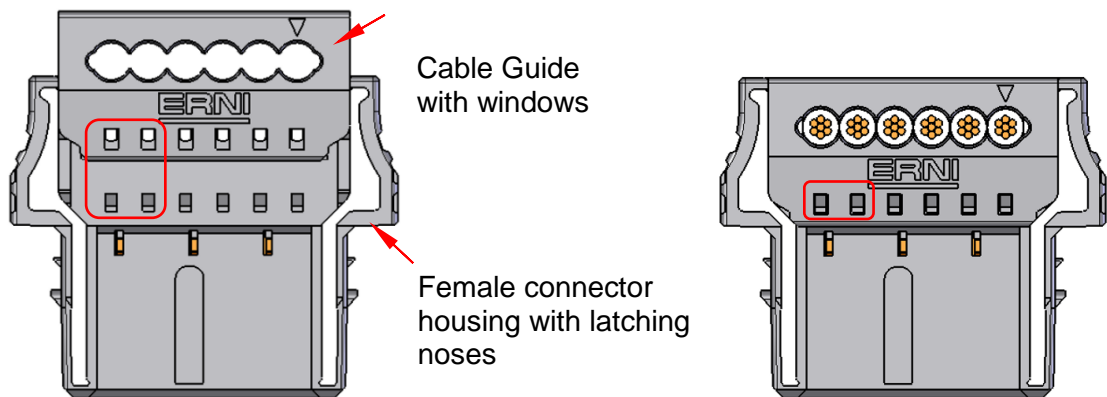

condition on delivery, open

Visibility of final locking of cable guide

180° Cable Outlet

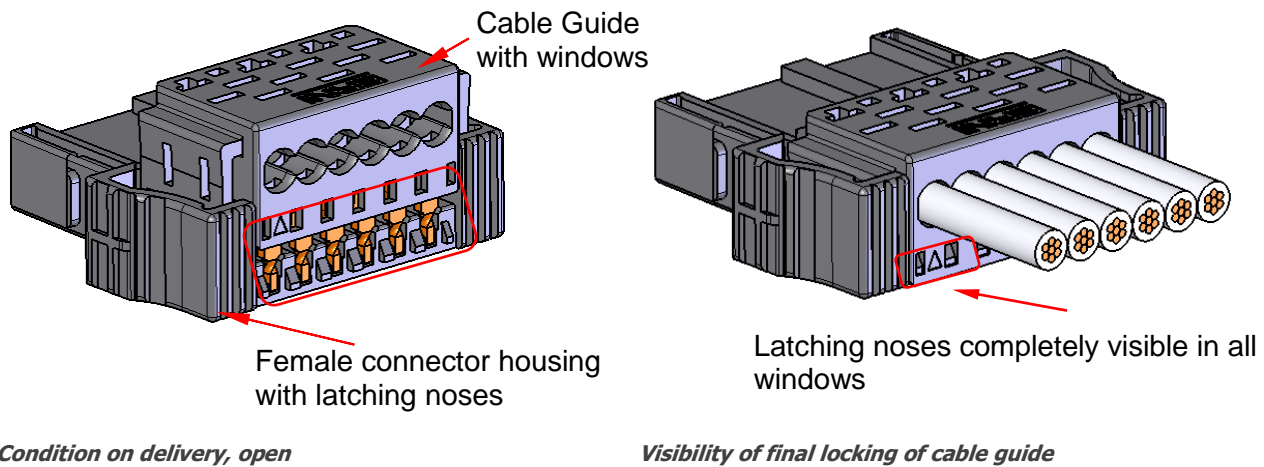

7.5 Pressing (Closing) the Connectors

In this section there are important guidelines for the design of connector holding fixtures (Lower Tool) and pressing rams (Upper Tool) which need to be observed unconditionally. If disregarded, there is the possibility that connectors may not reach their properties guaranteed by ERNI!

7.5.1 90° cable outlet

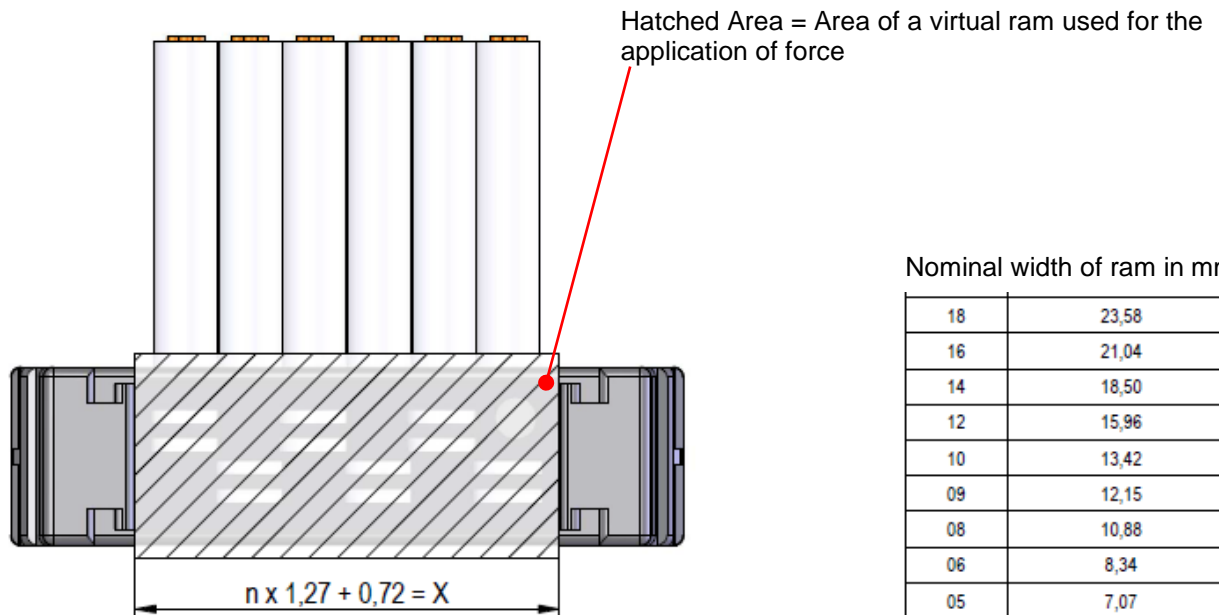

Tolerance of left and right outer edge:
both +0.0/-0.1

Nominal width of ram in mm

18	23,58
16	21,04
14	18,50
12	15,96
10	13,42
09	12,15
08	10,88
06	8,34
05	7,07
04	5,80
03	4,53
02	3,26
Pin Count	$n \times 1,27 + 0,72 = X$

Note: An area of support wider than that specified above is not allowed for the application of pressing force during processing, while for the mating face side a full-faced support plane is explicitly needed.

While pressing the connector housings, a Shut Height that depends from the number of poles shall be reached based on the following table:

Pin Count	Absolute Nominal Shut Height - A (Tool Opening at Bottom Dead Center)
Polzahl	Absolutes Verpressmaß - A (WZG-Öffnung am unteren Totpunkt - Schließhöhe)
2	10,8
3	10,8
4	10,8
5	10,8
6	10,8
8	10,7
10	10,7
12	10,6
14	10,6
16	
18	Inquire ERNI / ERNI anfragen
20	

Tolerance of Shut Height **A** for all numbers of poles: +/-0.03 mm.

Definition Dimension **A** (exemplary visualisation):

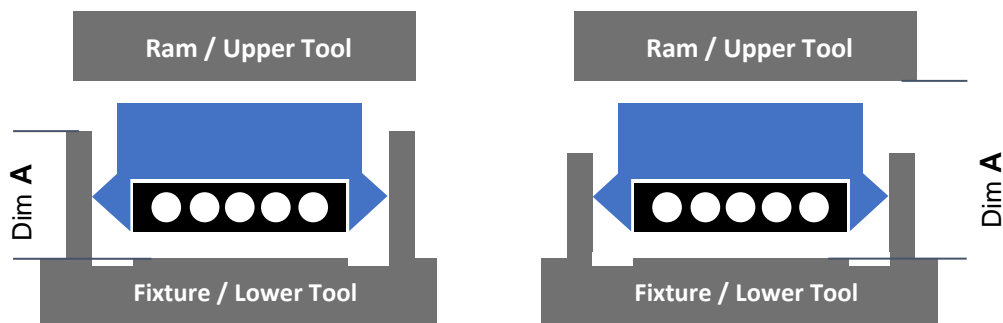

Fixture-limited tooling setup

Stroke-limited tooling setup

Note: Shut Height **A** is the dimension effective directly at the connector housing.

Note: In fixture-limited tooling setups the Shut Height (A) can be maintained independently of the press system.

Note: In stroke-limited tooling setups, the tolerance of dimension **A** has to be strictly maintained, as well.

Note: The connector housing must not be tilted during the pressing process in any one of the four directions.

7.5.2 180° cable outlet

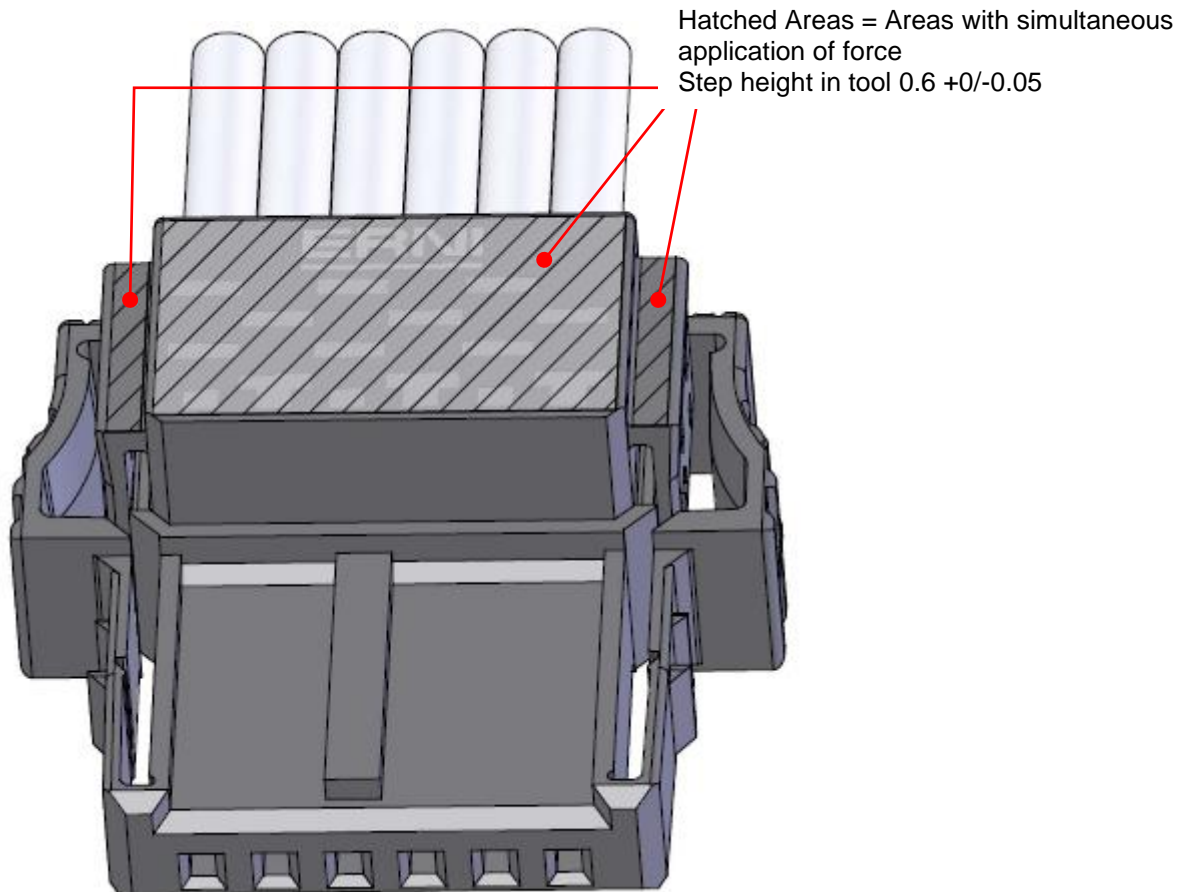

7.5.3 Connector Housing Orientation during Pressing (Closing) the Housings

An implementation of the tool dependent from the number of poles is needed on the side of the cable guide in general. If the cable guide is orientated downward during processing, all dependencies from the number of poles can be isolated in the connector holding fixture (bottom) and a flat rock tool (below left side) independent from the number of poles can be used for pressing from the top.

This is true for the 180° (straight) and the 90° (angled) version of the receptacles. In the following schematical depiction a 90° cable outlet is shown.

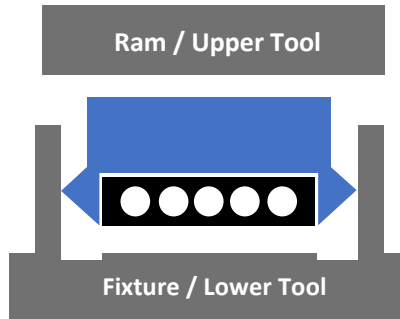

Processing with cable guide down

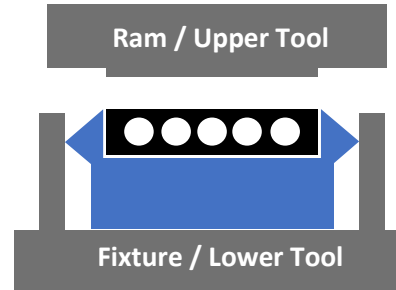

Processing with cable guide up

7.5.4 Check Dimension For Closed Connectors

In the course of the fabrication of assemblies the following check dimensions (closing dimensions) of fully closed housings are to be monitored, ensured and achieved.

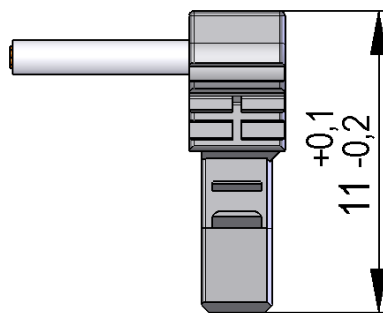

90° cable outlet

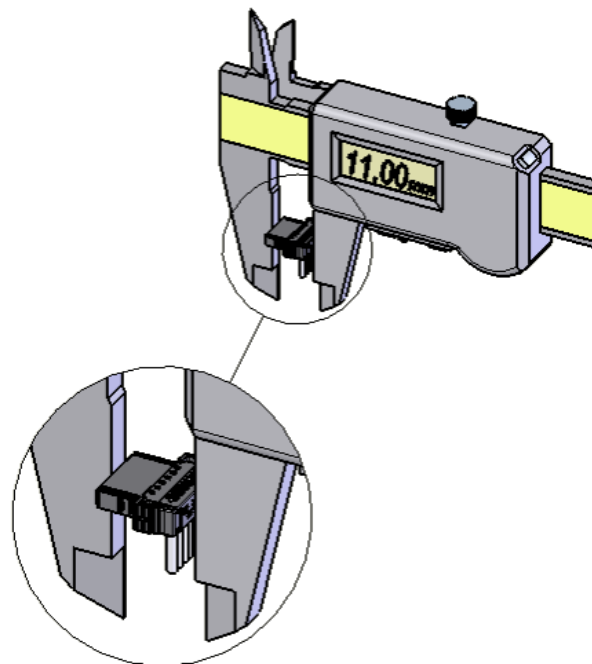

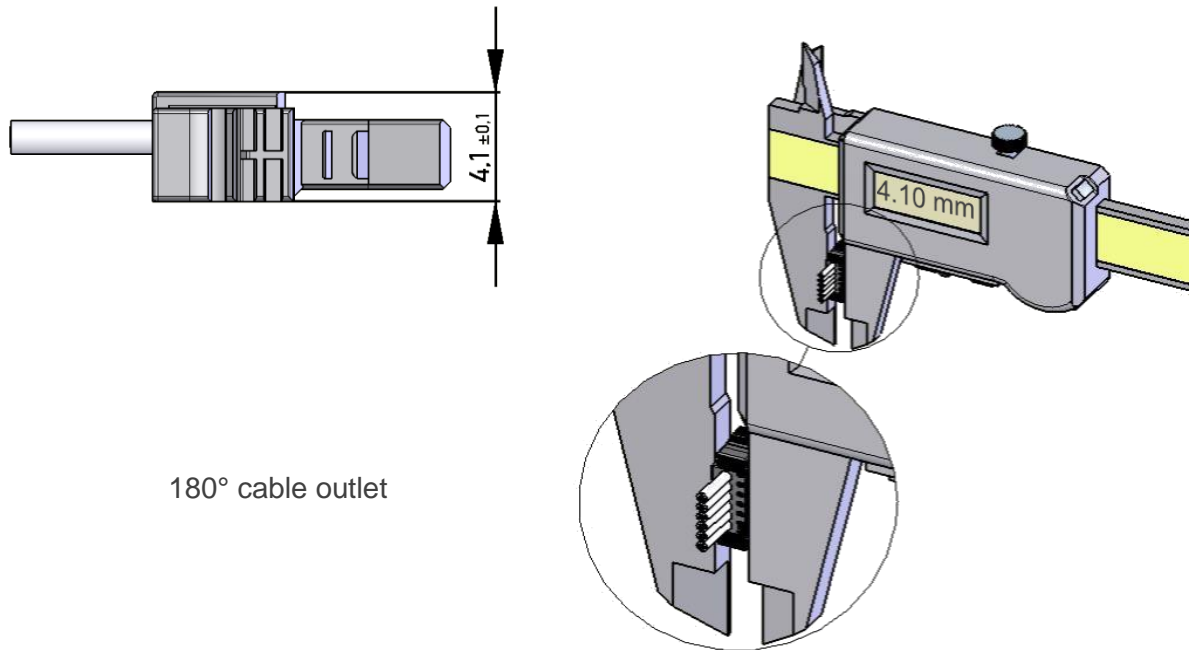

Note: While taking measurements connector orientation must be as depicted above.

8 Inspection

8.1 Applicable Inspections for Quality Assurance

Insulation Displacement Fixtures – Quality Assurance Matrix (Inspection Methods and Inspection Characteristics)					
#	Inspection Characteristics	Method	Inspection Type	During Production	
				Sample	100%
1	Mechanical damage	Assessment of appearance	Visual Inspection (semi-automatic / fully automatic machine)	X	
			Visual Inspection (manual fabrication)		X
2	Cable assignment (color identification)	Assessment of wire color	Suitable sensorics / Image processing (semi-automatic / fully automatic machine)		X
			Visual Inspection (manual fabrication)		X
3	Orientation	Assessment based on mechanical shape	Mechanical test (Poka Yoke) (semi-automatic / fully automatic machine)		X
			Visual Inspection (manual fabrication)		X
4	Displacement of insulation (cutting)	Assessment of appearance	Visual Inspection (semi-automatic / fully automatic machine)	X	
			Visual Inspection (manual fabrication)	X	
5	Undercut / Wire position in cable guide	Assurance by controlled insertion of wires into the cable guide	Path measurement within process		X
		Automatic Optical Inspection (AOI) within visible boundaries, Assessment by sensorical or mechanical scanning	Image processing, sensorical or mechanical		
		Assessment of appearance (based on limiting sample)	Visual Inspection	X	
6	Locking of the housing	Assessment of appearance	Visual Inspection	X	
			Achieving the check dimension ¹ (closing dimension)		X ²

7	Check dimension (Closing dimension)	Dimensional check	Path measurement within process / Assure in process ¹		X
			Mechanical measurement	X	
8	Retention force	Dimensional check / measurement (destructive)	Pull-out strength (single conductor only)	X	
9	Short circuit & isolation	Dimensional check / measurement	Electrical test within process or subsequent test		X
10	Continuity (connector attached at both wire ends)	Dimensional check / measurement	Electrical test within process or subsequent test		X

1) to be ensured by tool and equipment – refer to requirements in Chapter 7.5

2) see check dimension (closing dimension)

8.2 Notes on Electrical Testing

A suitable contact pin has to be used for adaptation for electrical testing, with a probe head shape that permits contacting without damaging the female contact springs.

Alternatively, a male MicroBridge connector soldered onto a circuit board can be used for electrical testing. Steps should be taken to prevent latching for an optimal test process.

For isolation testing a high voltage is decisively. ERNI recommends 500 V for a duration of 0.3 to 0.5 s.