

Attachment 2. Means Of Production

Pressure Pieces	Column Mount
272601 pressure piece (upper tool) for all pin counts 90° (narrow)	272600 column mount
342040 pressure piece (upper tool) for all pin counts 180° (wide)	
Holder Female 90°	Holder Female 180°
272271 90° holder for 2 pins	342020 180° holder for 2 pins
272273 90° holder for 4 pins	342022 180° holder for 4 pins
272274 90° holder for 5 pins	342023 180° holder for 5 pins
272275 90° holder for 6 pins	342024 180° holder for 6 pins
272277 90° holder for 8 pins	342026 180° holder for 8 pins
	342027 180° holder for 9 pins
272279 90° holder for 10 pins	
272281 90° holder for 12 pins	
272283 90° holder for 14 pins	
	342034 180° holder for 16 pins

Set-up of Means of Production:

Accordingly:

- Pressure Piece (upper tool) 90°
- Pressure Piece (upper tool) 180°

Accordingly:

- Holder Female 90°
 - Holder Female 180°
- For respective pin count

Column Mount

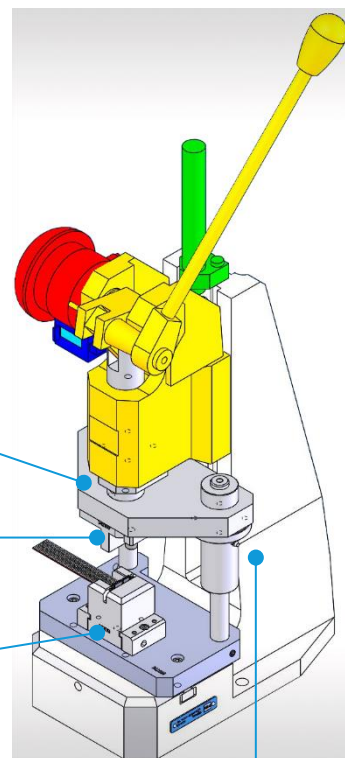

Optionally:

- Toggle Press
e.g. Type No. 11 from
Schmidt Technology GmbH
Feldbergstr. 1
78112 St. Georgen (Germany)

**Remarks:**

All processing shall strictly follow ERNI's Processing Specification in order to ensure best quality.

ERNI reserves the right to apply changes to this document without prior notice.

The released version of a Processing Specification can be obtained by download from www.erni.com. The edition on the website replaces all older versions, which hereby become invalidated. Make sure you regularly check there for more recent issues. If, in rare cases, the Processing Specification is not available online, please contact your local ERNI representative. This also applies to the Processing Specifications' attachments which may change independently from the main Processing Specification.