

ASSEMBLY INSTRUCTION

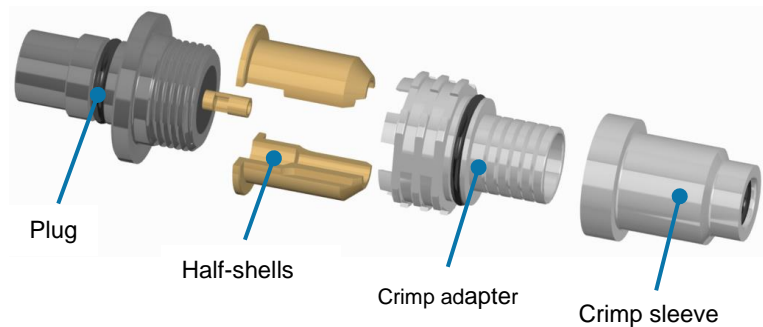

ODU AMC[®] High-Density Coaxial connector break-away plug

1. Cable assembly



Size	max. cable \varnothing mm
00 (C)	3.1

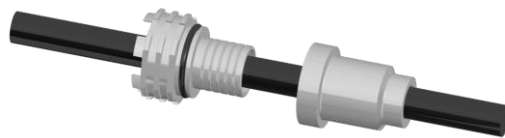

1. Slide crimp sleeve and crimp adapter over the cable.



Fastening tape
ODU advise Crepe masking tape
e.g. Würth: 09920019

2. Strip the cable and conductors. Fold back the shield and use fastening tape to fasten it to the cable jacket. Tin-plate this wires if needed.



3. Solder the inner conductor to the contact. Clean the solder area with Isopropylalcohol and brush.



4. Assemble the half-shells.

ASSEMBLY INSTRUCTION

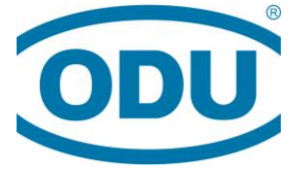

ODU assembly tool
(on request)

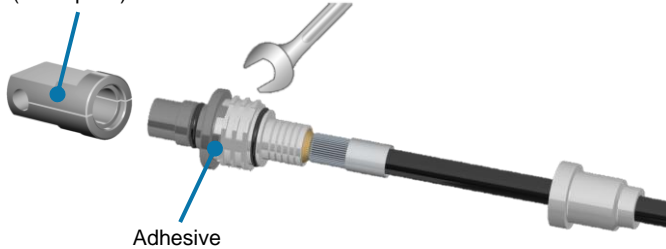

5. Screw the crimp adapter on so that it is flush, observing torque values (see page 4). Secure the screw thread with adhesive. If necessary use the assembly tool (see 3.2).



6. Remove the fastening tape and lay the shield braid on to the crimp adapter. Fasten the shield braid to the crimp adapter by means of crimping.



7. Bend relief: This can be implemented by means of overmolding or by using a shrink tube.

Sealing surface for cable overmolding

ASSEMBLY INSTRUCTION



2. Cable Preparation

The following table provides recommended guidelines for cable preparation. The according stripping measures have to be checked before assembly!

recommended cable preparation

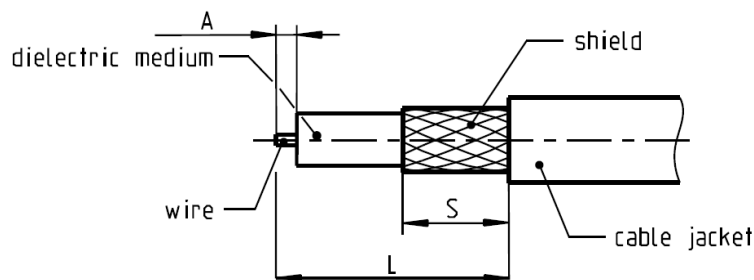

Size	Contact \varnothing	L	A	S
00	0.7	9	3	9

Stripping lengths cable jacket (L)	
Length in mm	Tolerance in mm
< 20	± 1
> 20 - 50	± 2
> 50 - 100	± 3

Stripping length braided shield (S)	
Length in mm	Tolerance in mm
< 10	± 1
> 10 - 20	± 2

Stripping lengths single conductor (A)	
Length in mm	Tolerance in mm
< 5	± 0.5
> 5 - 10	± 1
> 10 - 20	± 2

Exceptions are noted on special instructions.

ASSEMBLY INSTRUCTION



3. Assembly crimp adapter

Size	Torque Nm	Reference Dimension X mm
00 (C)	0.5	13.0

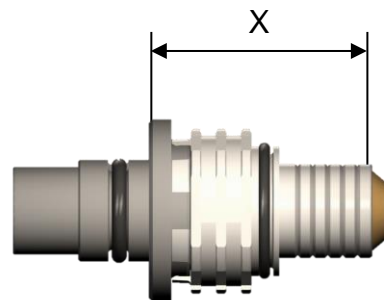

3.1 Spann wrench

Size	Part number	Wrench size
00 (C)	598.700.001.001.000	8

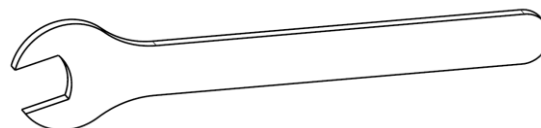

3.2 Assembly tool

Size	Part number
00 (C)	713.650.902.631.000

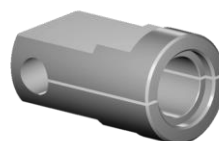

3.3 Adhesive

Secure the crimp adapter on housing with adhesive.
(ODU reference: Loctite 5776)

ASSEMBLY INSTRUCTION



4. Assembly crimp sleeve

4.1 Crimp tool ODU

Hand-crimp tool	
Size	Part number
all	080.000.026.000.000

Crimp dies	
Size	Part number
00 (C)	080.000.026.713.002

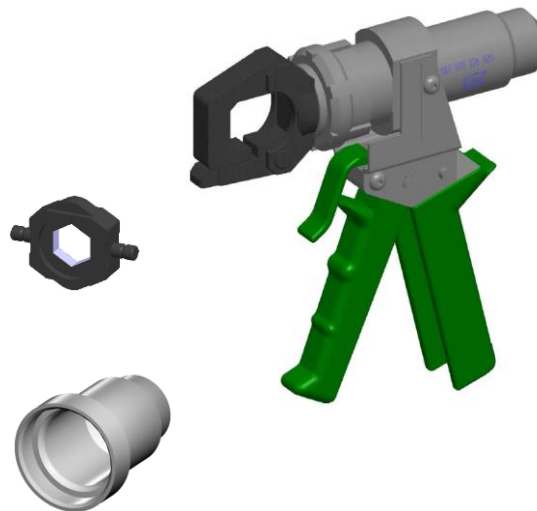

5. Cable interface

ODU provides three different solutions for the cable interface. According to the requirements the customer can choose between overmolding, heat shrinkable molded parts and heat shrinkable tubing.

5.1 ODU overmolding (recommended series solution)

ODU provides complete solutions with straight overmoldings on request.



Example image: Break-Away Plug and In-Line Receptacle (size 00)

ASSEMBLY INSTRUCTION



5.2 Heat shrinkable molded parts (samples, pre-series)

Size	Part number		Min. cable Ø in mm
	ODU	Supplier	
00 (C)	921.000.010.008.103	202K111-25 (Tyco)	3.0

To a better adhesion of the heatshrink boots on housing and cable, ODU recommends to work with an epoxyd-adhesion (e. g. Hellermann V9500, Raychem S1125).



Example image: Break-away plug and in-line receptacle (size 1)

5.3 Heat shrinkable tubing (samples, pre-series)

Size	Part Number		Min. cable Ø in mm
	ODU	Tyco	
00 (C)	921.000.010.008.093	ATUM-12/3	3.0

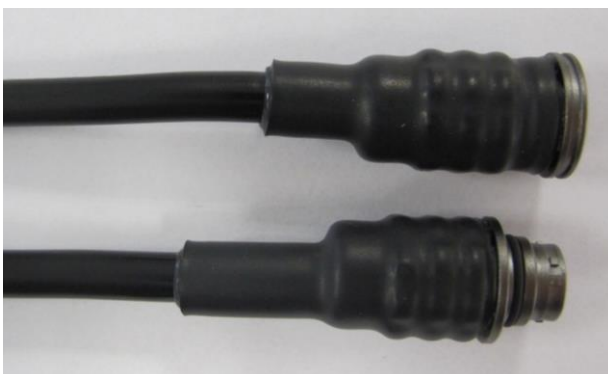

Example image: Break-away plug and in-line receptacle (size 1)