

6

5

4

3

2

1

D

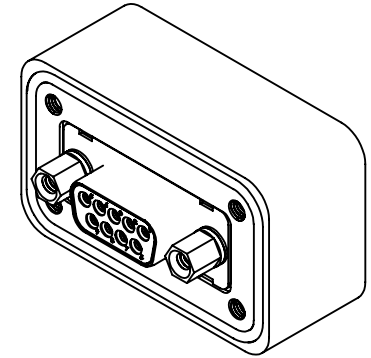
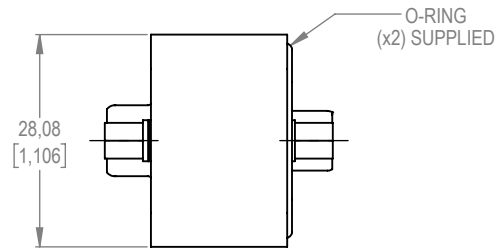
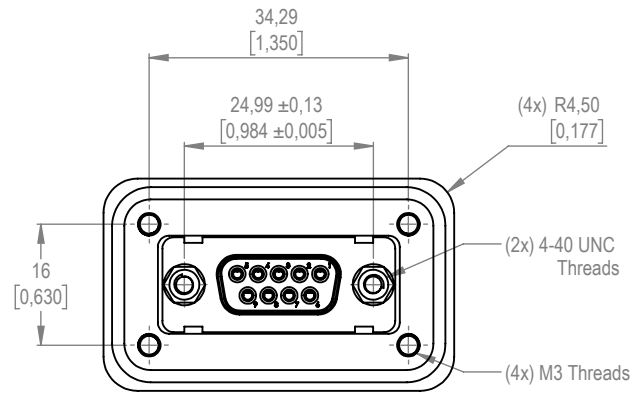

D

C

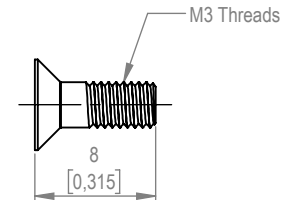
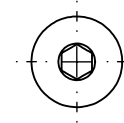
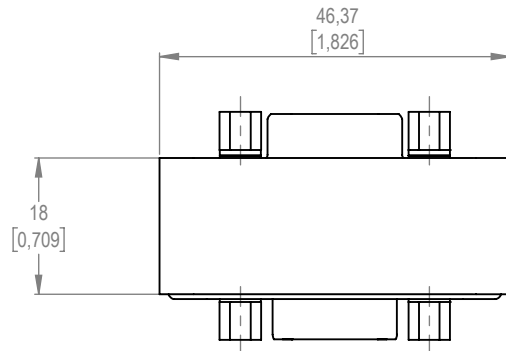

C

B

MATERIAL AND FINISHES:

INSULATOR : GLASS-FILLED DAP PER ASTM-D-5948.
 CONTACTS M/S: PRECISION MACHINED COPPER ALLOY WITH 1.27µ [0.000050 inch] GOLD OVER COPPER PLATE.
 SHELLS : STAINLESS STEEL, PASSIVATED.
 HOUSING : ALUMINIUM ALLOY, GOLDEN BROWN CONVERSION COATING.
 JACKSCREWS : STAINLESS STEEL, PASSIVATED.
 WASHERS: STAINLESS STEEL, PASSIVATED.
 O-RING : FLUOROCARBON, BLACK COLOR. (ONE MOUNTING AND ONE FOR SPARE PART).
 FIXATION SCREWS : STAINLESS STEEL, PASSIVATED (KITTED).
 DUST COVER: CONDUCTIVE LOW DENSITY POLYETHYLENE (KITTED).

B

A

PANEL CUT-OUT INFORMATIONS

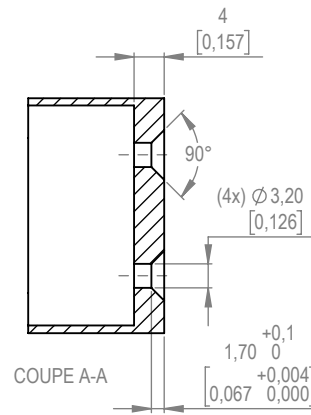
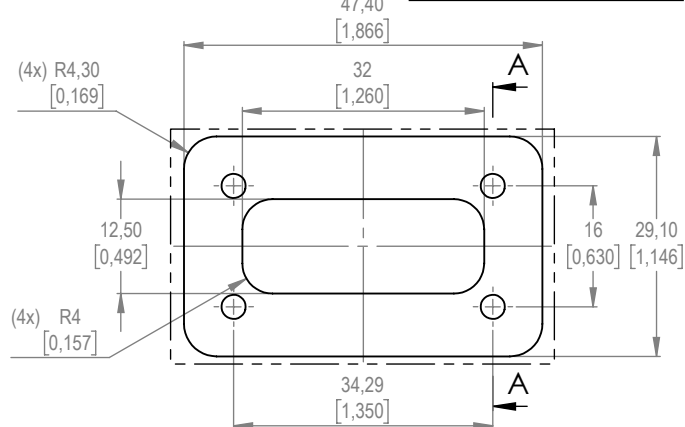

DETAIL PRODUCT, ELECTRICAL AND MECHANICAL INFORMATION IS AVAILABLE IN THE LATEST XAVAC PRODUCT AT CONNECTPOSITRONIC.COM.

DRAWING NO.	PART NUMBER	REMARKS
PSK2999-1	XAVAC9M/SI.0	-
PSK2999-2	XAVAC9M/SI.0/AA	RoHS COMPLIANT TO THE CURRENT RoHS DIRECTIVE.
LATEST REVISION		
BY A.Thurette	CHK R.Biane	3RD ANGLE
APR P.Pivetta	ECO CH 2957	
TOLERANCES		
±0.03mm [0.001 INCHES] FOR MALE CONTACT MATING DIAMETERS		
±0.08mm [0.003 INCHES] FOR CONTACT TERMINATION DIAMETERS		
±0.13mm [0.005 INCHES] FOR ALL OTHER DIAMETERS		
±0.38mm [0.005 INCHES] FOR ALL OTHER DIMENSIONS		
±5° FOR ALL ANGLES		
DIMENSION ARE IN MILLIMETERS [INCHES]		
SCALE		POSITRONIC BELIEVES THE DATA ON THE DRAWING TO BE RELIABLE. THE USER EMPLOYS SUCH INFORMATION AT HIS OWN DISCRETION AND RISK. POSITRONIC ASSUMES NO RESPONSIBILITY FOR RESULTS OBTAINED OR DAMAGES INCURRED FROM USE OF SUCH INFORMATION IN WHOLE OR IN PART.
NTS		
PART NUMBER		SERIES HERMETIC
XAVAC9M/SI.0 / XAVAC9M/SI.0/AA		
TITLE PSK2999-*		
DATE 27/07/2017	SHEET SHEET 1 OF 1	REV A

A

6

5

4

3

2

1