

PANEL CUT-OUT INFORMATION

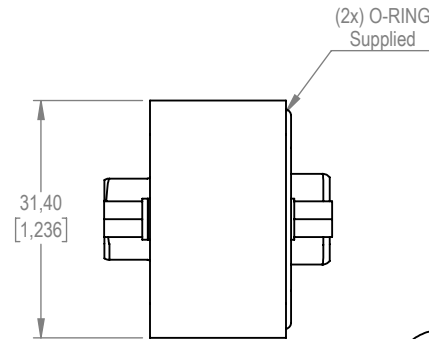

(4x) SCREWS KITTED

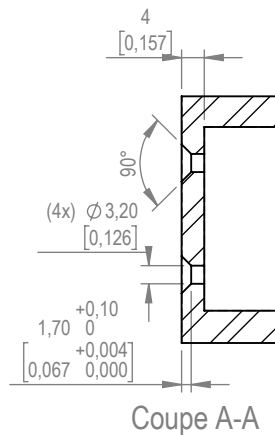
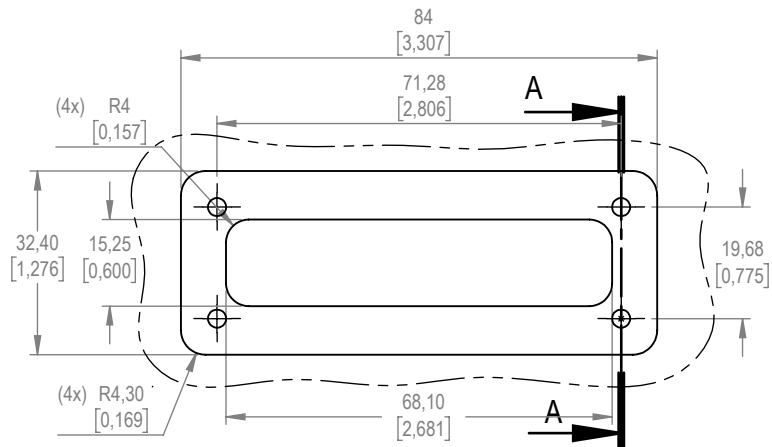
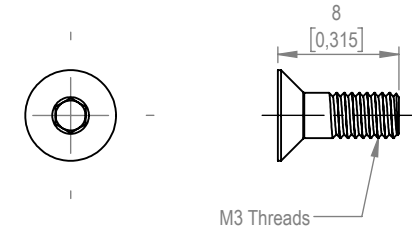

NOTES:

1. MATERIALS AND FINISHES:

- INSULATOR : GLASS-FILLED DAP PER ASTM-D-5948 OR POLYESTER GLASS-FILLED PER ASTM D5927, UL94V0, ASTM E-595, NASA-RP-1124.
CONTACTS M/S: PRECISION MACHINED COPPER ALLOY WITH 1.27µ [0.000050 inch] GOLD OVER COPPER PLATE.
SHELLS : STAINLESS STEEL, PASSIVATED.
HOUSING : ALUMINIUM ALLOY, GOLDEN BROWN CONVERSION COATING.
JACKSCREWS : STAINLESS STEEL, PASSIVATED.
WASHERS: STAINLESS STEEL, PASSIVATED.
O-RING : FLUOROCARBON, BLACK COLOR.
(ONE MOUNTING AND ONE FOR SPARE PART).
FIXATION SCREWS : STAINLESS STEEL, PASSIVATED (KITTED).
DUST COVER: CONDUCTIVE LOW DENSITY POLYETHYLENE (KITTED).

2. DETAIL PRODUCT, ELECTRICAL AND MECHANICAL INFORMATION IS AVAILABLE IN THE LATEST XAVAC PRODUCT PUBLICATION AT CONNECTPOSITRONIC.COM.

DRAWING NO.	PART NUMBER	REMARKS
PSK2300-1	XAVAC50M/SI.0	-
PSK2300-2	XAVAC50M/SI.0/AA	RoHS COMPLIANT TO THE CURRENT RoHS DIRECTIVE.
LATEST REVISION		
BY A.Thurette	CHK R.Biane	3RD ANGLE
APR P.Pivetta	ECO CH 2957	
TOLERANCES		SCALE NTS
±0.03mm [0.001 INCHES] FOR MALE CONTACT MATING DIAMETERS ±0.08mm [0.003 INCHES] FOR CONTACT TERMINATION DIAMETERS ±0.13mm [0.005 INCHES] FOR ALL OTHER DIAMETERS ±0.38mm [0.005 INCHES] FOR ALL OTHER DIMENSIONS ±5° FOR ALL ANGLES DIMENSION ARE IN MILLIMETERS [INCHES]		PART NUMBER XAVAC50M/SI.0 / XAVAC50M/SI.0/AA
		SERIES HERMETIC
TITLE PSK2300-*		
DATE 27/07/2017	SHEET SHEET 1 OF 1	REV B

POSITRONIC BELIEVES THE DATA ON THE DRAWING TO BE RELIABLE. THE USER EMPLOYS SUCH INFORMATION AT HIS OWN DISCRETION AND RISK. POSITRONIC ASSUMES NO RESPONSIBILITY FOR RESULTS OBTAINED OR DAMAGES INCURRED FROM USE OF SUCH INFORMATION IN WHOLE OR IN PART.

